

FUJITSU GENERAL ELECTRONICS LIMITED

FGI-6I035C120C1

IGBT MODULE

1200V/35A IPM

- Features
 - Can be mounted by replacing with a package made by another company and pin compatible. (Overcurrent setting is set internally.)
 - Bootstrap diode built-in.
 - SW speed and built-in protection circuit threshold adjustable.

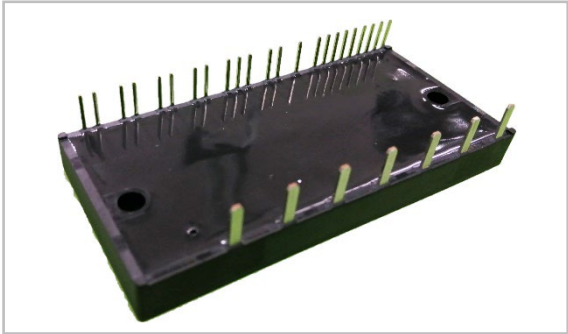

- Usage

AC400V motor control inverter unit.

- Dimensions

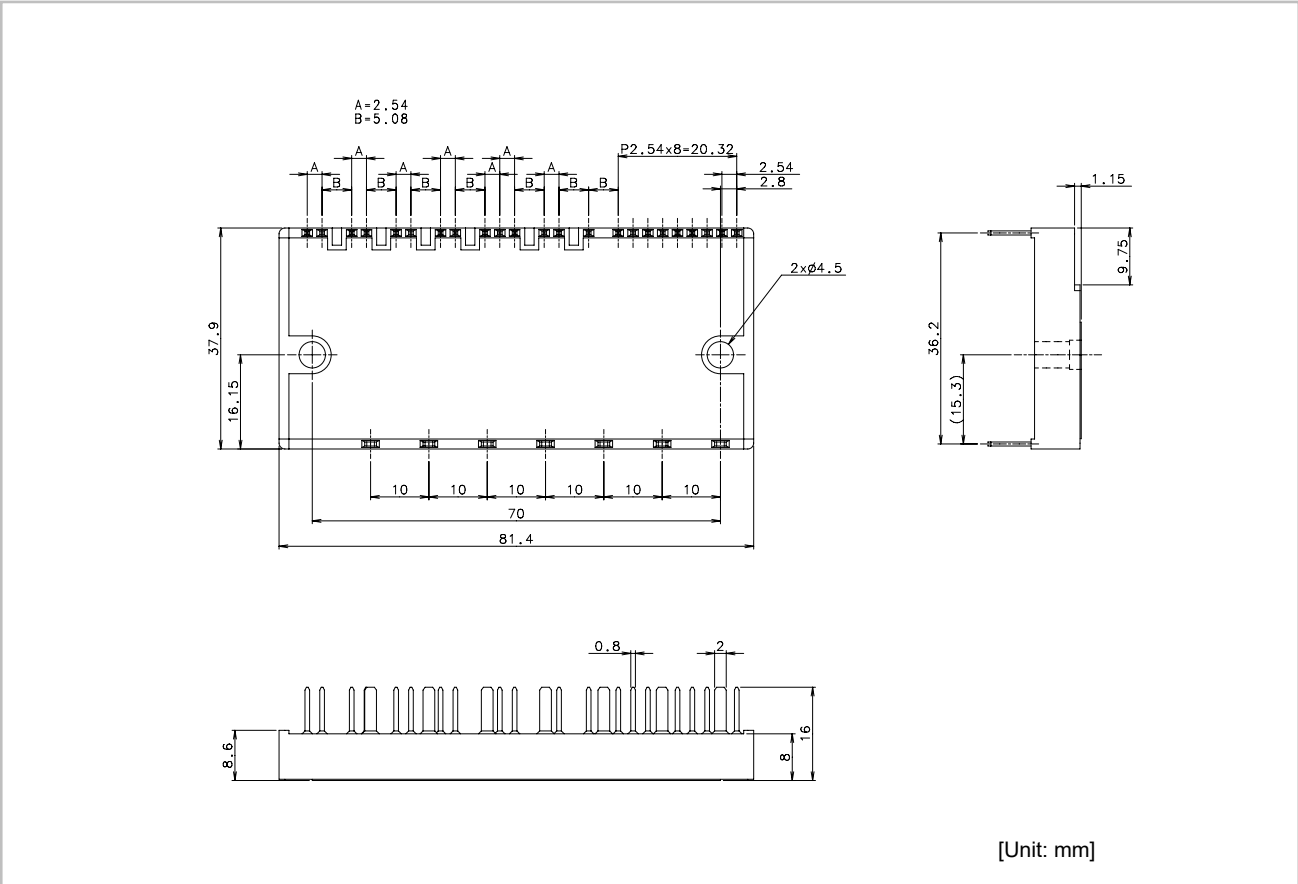

Fig.1. Dimensions

FGI-6I035C120C1

■ Pin Functions

Pin No.	Name	Function	Pin No.	Name	Function
1	U _P	Signal Input for High-side U-phase	22	V _{NC}	Control Supply GND for Low-side
3	V _{P1}	Control Supply for High-side U-phase	23	V _{OT}	Temperature Sensor Output
4	V _{UFB}	High-side Bias Voltage for U-phase IGBT Driving	24	C _{IN}	Protection Circuit Input Terminal
6	V _{UFS}	High-side U-phase Drive Supply GND	25	N.C.	No Connect
7	V _P	Signal Input for High-side V-phase	26	F _O	Fault Output
9	V _{P1}	Control Supply for High-side V-phase	27	U _N	Signal Input for Low-side U-phase
10	V _{VFB}	High-side Bias Voltage for V-phase IGBT Driving	28	V _N	Signal Input for Low-side V-phase
12	V _{VFS}	High-side V-phase Drive Supply GND	29	W _N	Signal Input for Low-side W-phase
13	W _P	Signal Input for High-side W-phase	34	NW	Negative Bus Voltage Input for W-phase
14	V _{P1}	Control Supply for High-side W-phase	35	NV	Negative Bus Voltage Input for V-phase
15	V _{PC}	Control Supply GND for High-side	36	NU	Negative Bus Voltage Input for U-phase
16	V _{WFB}	High-side Bias Voltage for W-phase IGBT Driving	37	W	W-phase Output
18	V _{WFS}	High-side W-phase Drive Supply GND	38	V	V-phase Output
19	N.C.	No Connect	39	U	U-phase Output
21	V _{N1}	Control Supply for Low-side	40	P	Positive Bus Voltage Input

FGI-6I035C120C1

■ Block Diagram

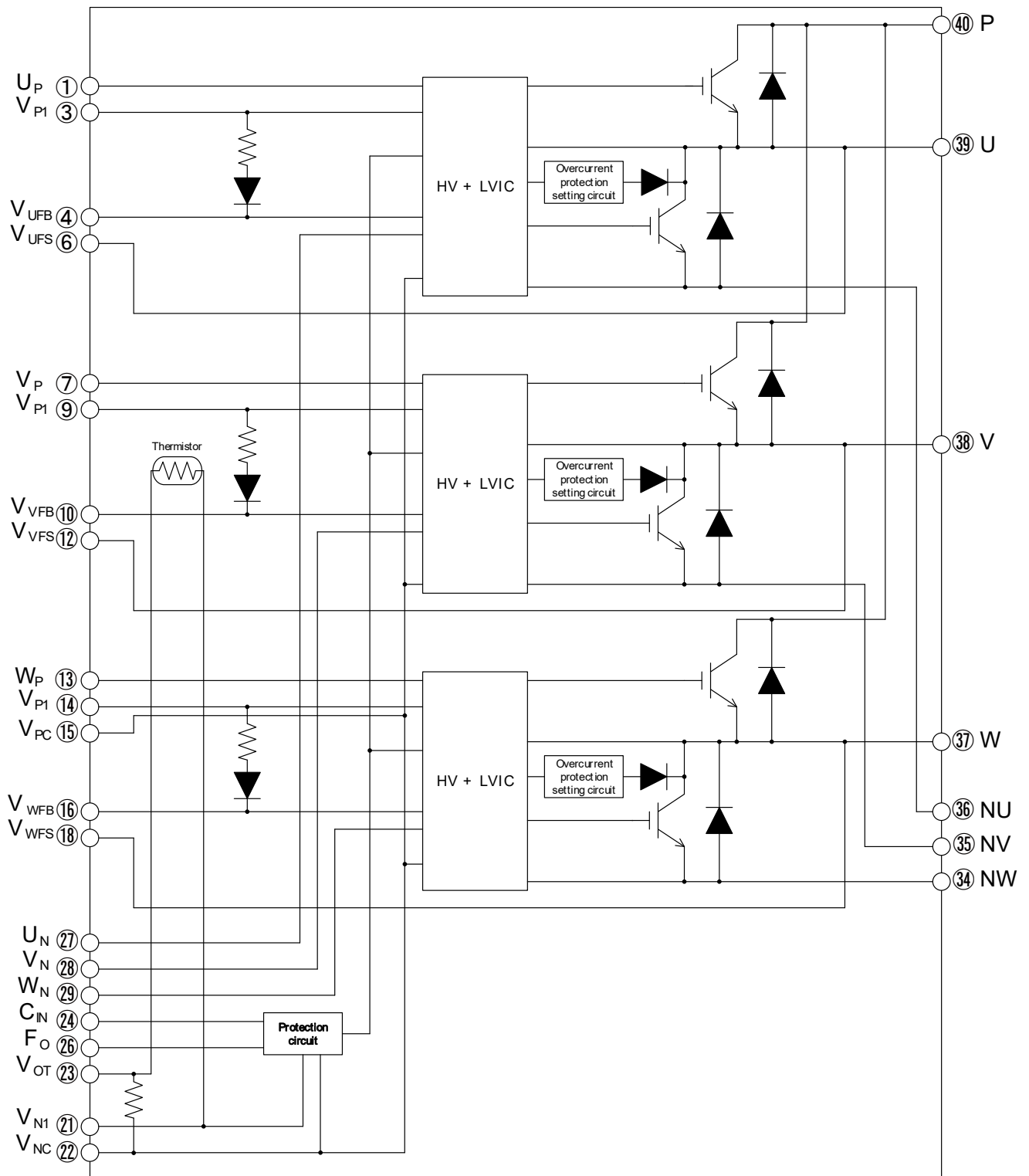

Fig.2. Block Diagram

FGI-6I035C120C1

■ Absolute Maximum Ratings (T_j=25°C、V_D=V_{DB}=15V unless otherwise specified)

Items			Symbol	Min.	Max.	Units	
Inverter Block	DC Bus Voltage		V _{CC}	-	(900)	V	
	Bus Voltage (Surge)		V _{CC(SURGE)}	-	(1000)	V	
	Collector-Emitter Voltage		V _{CES}	0	1200	V	
	Collector Current	DC	Forward	+I _C	-	35	A
			Reverse	-I _C	-	35	A
	Collector Current (Peak)	1ms	Forward	+I _{CP}	-	70	A
			Reverse	-I _{CP}	-	70	A
Collector Power Dissipation		1 device	P _C	-	147	W	
Junction Temperature			T _J	-	150	°C	
Circuit Block	Supply Voltage (High-side)	Applied between V _{P1} -V _{PC} , V _{N1} -V _{NC}	V _D	-0.5	20	V	
		Applied between V _{UFB} -V _{UFS} , V _{WFB} -V _{WFS} , V _{NFB} -V _{NFS}	V _{DB}	-0.5	20	V	
	Input Signal Voltage	Applied between U _P , V _P , W _P -V _{PC} , U _N , V _N , W _N -V _{NC}	V _{IN}	-0.5	VD+0.5	V	
Control	Fault Signal Voltage	Applied between F _O -V _{NC}	V _{FO}	-0.5	VD+0.5	V	
	Fault Signal Current	Sink current of F _O terminal	I _{FO}	-	5	mA	
General	Self Operation "DC Bus Voltage" of Circuit Protection Between Upper-arm and Lower-arm		V _D =13.5~16.5V, T _j =125°C, less than 2μs, non-reptitive	V _{CC(PROT)}	-	800	V
	Operating Case Temperature			T _C	-30	100	°C
	Storage Temperature			T _{stg}	-40	125	°C
	Isolation Voltage			Viso	-	AC2500	Vrms
Screw Torque		Mounting Screw : M4		-	1.47	N·m	

FGI-6I035C120C1

■ Electrical Characteristics (Tj=25°C, V_D=V_{DB}=15V unless otherwise specified)

Items		Symbol	Conditions	Min.	Typ.	Max.	Units	
Inverter Block	Collector-Emitter Saturation Voltage	V _{CE(sat)}	I _C =35A	Tj=25°C	-	1.83	2.35	V
				Tj=125°C	-	2.12	-	V
	Forward Voltage of FWD	V _{EC}	I _C =35A	Tj=25°C	-	2.27	2.99	V
				Tj=125°C	-	2.19	-	V
	Switching Times	t _{on}	V _{CC} =600V, I _C =35A, Tj=125°C V _{IN} =0↔5V Inductive load(between Upper-arm and Lower-arm)		1.9	2.4	2.6	μs
		t _{c(on)}			-	1.1	1.3	μs
		t _{off}			-	1.8	1.9	μs
t _{c(off)}				-	0.2	0.3	μs	
t _{rr}				-	0.5	-	μs	
Zero Gate Voltage Collector Current	I _{CES}	V _{CES}		-	-	1.0	mA	
Control Circuit Block	Control Circuit Current	I _D	Sum of V _{P1} -V _{PC} , V _{N1} -V _{NC}	V _{IN} =0V	-	-	8.0	mA
				V _{IN} =5V	-	-	20.0	
	Bootstrap Circuit Current	I _{DB}	V _{UFB} -V _{UFS} , V _{VFB} -V _{VFS} , V _{WFB} -V _{WFS}	V _{IN} =0V	-	-	1.4	mA
				V _{IN} =5V	-	-	1.4	
	Over Current Trip Level	I _{SC}	Tj=125°C		59.5	-	-	A
	Under Voltage Protection Leve of P-side	UV _{DBt}	Trip level		9.7	-	11.7	V
		UV _{DBr}	Trip level		10.5	-	12.5	V
	Under Voltage Protection Leve of N-side	UV _{Dt}	Trip level		7.0	-	11.0	V
		UV _{Dr}	Trip level		7.0	-	11.0	V
	Fault Output Voltage	V _{FOH}	F _O = 10kΩ, 5V pull-up		-	4.9	-	V
		V _{FOL}	I _{FO} = 1mA		-	-	0.95	V
	Fault Output Pulse Width	t _{FO}	-		-	2.40	-	ms
	Input Current	I _{IN}	V _{IN} =5V		0.6	1.0	1.4	mA
	Input Signal Threshold Voltage	V _{th(on)}	Applied between U _P , V _P , W _P -V _{PC} , U _N , V _N , W _N -V _{NC}	OFF→ON	-	-	4.0	V
V _{th(off)}		ON→OFF		1.0	-	-	V	
Output Voltage of Temperature Sensor	V _{OT}	Temperature of LVIC = 75°C		2.28	2.38	2.51	V	
Forward Voltage of Bootstrap Diode	V _F	I _{FB} = 10mA , Included voltage drop of limiting regisitance		-	0.75	-	V	
Built-in Limiting Resistor	R	In a bootstrap diode		31.4	33.0	34.7	Ω	

FGI-6I035C120C1

■ Thermal Characteristics (Tc = 25°C)

Items			Symbol	Min.	Typ.	Max.	Units
Junction to Case Thermal Resistance	Inverter	IGBT	$R_{th(j-c)Q}$	-	-	0.85	°C/W
		FWD	$R_{th(j-c)F}$	-	-	1.05	°C/W

■ Mechanical Characteristics and Weight

Items	Conditions	Standard	Min.	Typ.	Max.	Units
Mounting Torque	Mounting Screw : M4	-	0.98	-	1.47	N·m
Terminal tensile strength	Load 19.6N	JEIAJ-ED-4701	10	-	-	s
Bending strength of terminal	90 degree bend at 9.8N load	JEIAJ-ED-4701	2	-	-	times
Weight	-	-	-	66.5	-	g

Notice

Disclaimer of contents

Before you use our Products, you are requested to carefully read this document and fully understand its contents.

All information contained in this document is current as of the issuing date and subject to change without any prior notice. Before purchasing or using Fujitsu General Electronics Products, please confirm the latest information with a Fujitsu General Electronics sales or distributor. Please also pay attention to information published by Fujitsu General Electronic by various means, including the Fujitsu General Electronic home page (www.fujitsu-general.com/jp/fgel/).

The information contained in this document is provided on an "as is" basis and Fujitsu General Electronics does not warrant that all information contained in this document is accurate and/or error-free. Fujitsu General Electronics shall not be in any way responsible or liable for any damages, expenses or losses incurred by you or third parties resulting from inaccuracy or errors of or concerning such information.

All information and data including but not limited to application example contained in this document is for reference only. Fujitsu General Electronics does not warrant that foregoing information or data will not infringe any intellectual property rights or any other rights of any third party regarding such information or data.

The information contained in this datasheet shall in no event be regarded as a guarantee of conditions, characteristics or quality.

This product has to be used within its specified maximum ratings, and is subject to customer's compliance with any applicable legal requirement, norms and standards.

Customer's technical departments should take responsibility to evaluate the suitability of Fujitsu General Electronics Products for the intended application and the completeness of the product data with respect to such application. When using any or all of the information contained in these materials, including product data, diagrams, table, programs, and algorithms, please be sure to evaluate all information as a total system before making a final decision on the applicability of the information and products. Fujitsu General Electronics does not assume any liability for applicability.

As required, pay close attention to the safety design by installing appropriate fuse or circuit breaker between a power supply and semiconductor products to prevent secondary damage.

Fujitsu General Electronics are not designed or manufactured for use in a device or system that is used under circumstances in which human life is potentially at stake. Please contact Fujitsu General Electronics or an authorized Fujitsu General Electronics distributor when considering the use of a product contained herein for any specific purposes, such as apparatus or systems for transportation, vehicular, medical, aerospace, nuclear, or undersea repeater use.

In no event shall you use in any way whatsoever the Products and the related technical information contained in the Products or this document for any military purposes, including but not limited to, the development of mass-destruction weapons.

If these products or technologies are subject to the Japanese export control restrictions, they must be exported under a license from the Japanese government and cannot be imported into a country other than the approved destination.

Any diversion or re-export contrary to the export control laws and regulations of Japan and/or the country of destination is prohibited.

This document may not be reprinted or reproduced, in whole or in part, without prior written consent of Fujitsu General Electronics.

The Products may not be disassembled, converted, modified, reproduced or otherwise changed without prior written consent of Fujitsu General Electronics.

Fujitsu General Electronics shall not be in any way responsible or liable for failure induced under deviant condition from what is defined in this document.

The proper names of companies or products described in this document are trademarks or registered trademarks of Fujitsu General Electronics, its affiliated companies or third parties.

Intellectual property rights

The technical information described in this document shows characteristics of the product, applied circuits, etc. and does not imply assurance of the industrial property rights, etc. or permission of the execution rights.

Fail safe

If used exceeding the guaranteed values, we are not liable for any defect or breakdown that has happened after the use.

Fujitsu General Electronics designs and manufactures its Products subject to strict quality control system. However, semiconductor products can fail or malfunction at a certain rate. Please be sure to implement, at your own responsibilities, adequate safety measures including but not limited to fail-safe design against the physical injury, damage to any property, which a failure or malfunction of our Products may cause. Even if used within the guaranteed values, be sure to have redundancy design with which equipment using our product is not contrary to various laws due to operation of our product.

Applicable products

The technical information is intended for use in the following electronic and electrical equipment which has normal reliability requirements.

- Machine tools
 - Home appliances
 - Industrial robots
- etc.

If you need to use a product in this Catalog for equipment requiring higher reliability than normal, such as for the equipment listed below, it is imperative to contact Fujitsu General Electronics to obtain prior approval. When using these products for such equipment, take adequate measures such as a backup system to prevent the equipment from malfunctioning even if a Fujitsu General Electronics product incorporated in the equipment becomes faulty.

- Transportation equipment (mounted on cars and ships)
- Traffic-signal control equipment

- Emergency equipment for responding to disasters and anti-burglary devices
- Medical equipment
- Trunk communications equipment
- Safety devices

Do not use products for the equipment requiring strict reliability such as the following and equivalents to strategic equipment (without limitation).

- Space equipment
- Aeronautic equipment

Our Products are designed and manufactured for use under standard conditions and not under any special or extraordinary environments or conditions, as exemplified below. Accordingly, Fujitsu General Electronics shall not be in any way responsible or liable for any damages, expenses or losses arising from the use of any Fujitsu General Electronics' Products under any special or extraordinary environments or conditions. If you intend to use our Products under any special or extraordinary environments or conditions (as exemplified below), your independent verification and confirmation of product performance, reliability, etc., prior to use, must be necessary:

- [a] Use of our Products in any types of liquid, including water, oils, chemicals, and organic solvents
- [b] Use of our Products outdoors or in places where the Products are exposed to direct sunlight or dust
- [c] Use of our Products in places where the Products are exposed to corrosive gases
- [d] Use of our Products in places where the Products are exposed to static electricity or electromagnetic waves
- [e] Sealing or coating our Products with resin or other coating materials
- [f] Use of the Products in places subject to dew condensation

The Products are not subject to radiation-proof design.

Circumstances

In usage of power semiconductor, there is always the possibility that trouble may occur with them by the reliability lifetime such as Power Cycle, Thermal Cycle or others, or when used under special circumstances (e.g., condensation, high humidity, dusty, salty, highlands, environment with lots of organic matter/ corrosive gas / explosive gas, or situations which terminals of semiconductor products receive strong mechanical stress).

Therefore, please pay sufficient attention to such circumstances.

Further, depending on the technical requirements, our semiconductor products may contain environmental regulation substances, etc.

Please verify and confirm characteristics of the final or mounted products in using the Products.

Product performance and soldered connections may deteriorate if the Products are stored in the places where:

- [a] the Products are exposed to corrosive gases
- [b] the temperature or humidity exceeds those recommended by Fujitsu General Electronics

[c] the Products are exposed to direct sunshine or condensation

[d] the Products are exposed to high Electrostatic

Handling precautions

This Product is electrostatic sensitive product, which may be damaged due to electrostatic discharge. Please take proper caution in your manufacturing process and storage so that voltage exceeding the Products maximum rating will not be applied to Products. Please take special care under dry condition.

Even under Fujitsu General Electronics recommended storage condition, solderability of products out of recommended storage time period may be degraded. It is strongly recommended to confirm solderability before using Products of which storage time is exceeding the recommended storage time period.

Store / transport cartons in the correct direction, which is indicated on a carton with a symbol. Otherwise, bent leads may occur due to excessive stress applied when dropping of a carton.

Contact

Since concerned goods might be fallen under listed items of export control prescribed by Foreign exchange and Foreign trade act, please consult with Fujitsu General Electronics in case of export.